

HAMTRONICS® LPA 4-10R UHF REPEATER POWER AMPLIFIER

GENERAL INFORMATION.

The LPA 4-10R is designed to be installed as an integral part of a transmitter enclosure in a repeater installation with a two Watt exciter module. The transistor is biased for class-C operation to give 8-10 Watts output. The LPA 4-10R operates on +13.6 Vdc at about 2 Amp. It has a 50-ohm input and output impedance and is designed for continuous duty.

CONSTRUCTION.

Most of the pertinent construction details are given in the component location and schematic diagrams and parts list. All parts are tack soldered to the pc board; so it is necessary to cut and form leads so that they seat properly on the board and be sure to keep leads as short and direct as possible.

Note: This series of power amplifiers is designed to be mounted in an rf tight enclosure with the exciter in such applications as our REP-200 Repeater or an RF Tight box. The unit is supplied less heatsink and mounting hardware, since the enclosure acts as a heatsink and the hardware normally is provided with the repeater kit. If you have purchased the PA for some other use or mounting method, it is important to assemble and use the unit as we do in the repeater to avoid damage to the transistor by pulling the leads off the ceramic case. The LPA 4-10R is designed to have the thickness of a standard #8 SAE flat washer or two thin #4 flat washers (about 0.050 inch total) as a spacer between the pc board and the chassis which the transistor is mounted on.

a. If you are supplying your own enclosure, mark and drill four clearance holes for mounting the board with 4-40 screws and one 8-32 clearance hole to mount the transistor in the center of the cutout in the board. The latter hole must be close to the diameter of the xstr stud to provide maximum surface for the shoulder of the transistor to contact the chassis for heatsinking; so do not make this hole oversize.

b. Install four 4-40 x 3/8 inch screws from the bottom of the enclosure. Place flatwashers as spacers over the screws, as previously described.

c. Set pc board over screws, and align so cutout for transistor is centered over hole in enclosure. Secure

the board with 4-40 nuts and lock-washers.

d. Carefully open the package of heatsink compound with scissors. Use a toothpick or small piece of wire to apply a small amount of compound to the shoulder of the transistor where it contacts the heatsink.

e. Set the transistor in place, and orient the notched collector lead to the right as shown. Secure transistor with #8 lockwasher and 8-32 nut. Do not overtighten nut; tighten only to the point of being snug. Hold transistor leads with fingers to prevent rotation. If leads still rotate, you are probably applying too much torque.

Note: Since heatsink compound is used, it is unnecessary to use a lot of torque, which could break the stud.

f. Form the transistor leads down against the board. Then, tack solder them to the foil, using sufficient solder so that a bond is formed under the full length of the leads. Note that other parts will be soldered on top of the base and collector leads; so it helps to thoroughly flood those leads with solder.

g. Cut tabs of variable mica capacitor C6 and piston variable capacitors C2, C3, C7, and C8 as shown in the detail on the component location diagram, and solder them to the board in the exact positions shown. Doing so leaves adequate space for coil connections. Mount the capacitors oriented as shown so the rotor screw is connected to the proper side of the circuit.

Note: There are two sizes of bus wire in the kit: #22 is the finest and #14 is the heaviest.

h. Ferrite choke Z2 is threaded with 2-1/2 turns of #22 bus wire, as shown in the detail, by feeding the wire through opposite holes and pulling tight. One hole will not be used. Be sure to wind the wire as shown, not in a zig-zag fashion. The choke is mounted flat against the pc board, and the leads are tack soldered to the board.

i. Tack solder R2 across Z2 as shown, being careful not to short to turns on the choke.

j. Install chip capacitors as follows. Use small tweezers to handle them. *Be careful not to drop them; they are difficult to find. Since they have no markings, be sure to leave them in the package until installed so you can tell the values apart.* Note

where capacitors are to be positioned. The chip capacitors must straddle the area between the pad and the ground plane, with one electrode soldered to each.

Apply a little solder to the pads adjacent to the transistor leads where one end of each capacitor will be positioned. Do not apply solder to the ground plane yet.

Pick up one capacitor at a time. Set the capacitor in place. Then, heat the solder on the pc board pad, and allow the solder to bond to the electrode on the capacitor. When the solder melts, the capacitor will seat down on the board in the molten solder. It is essential that this process be done relatively quickly so the solder doesn't oxidize and so there is still a little flux left where the capacitor electrode sits.

After one end of each of the capacitors is soldered and the positions have been confirmed to be correct, solder the ground plane end of each capacitor.

k. Wind the coils exactly as specified in the component location diagram, and tack solder them to the board. Note that all pertinent details of coil winding are given in the diagram. Any rod of the proper diameter (such as the shank of a drill bit) can be used as a forming tool for coil winding.

l. Tack solder electrolytic capacitor C12. Bend the leads at right angles, and observe polarity.

m. Tack solder R1 and L5 as shown. Ferrite bead Z1 is installed on the ground lead of choke L5.

n. Check to be sure all parts are installed according to parts list, and check all solder connections.

RF INPUT/OUTPUT CONNECTIONS.

The input and output connections are made with RG-174/u 50-ohm coax cable connected to the appropriate input and output pads and ground plane of the pc board. Lengths shown assume that PA will be installed in REP-200 Repeater or an A16 RF Tight Box. Connect cables by stripping as illustrated and tack-soldering to board. Note that stripped length of coax is inductive; so keep leads short and neat.

Connect the shields by pretinning all around the shield and then tack soldering just the part of the shield which contacts the board. Avoid melt-

ing polyethelene insulation on cable by pretinning board and cable and then tacking them together quickly.

POWER CONNECTIONS.

+13.6Vdc should be connected to the B+ pad at the top of the pc board. When installed in an REP-200 Repeater, a hookup wire should be attached to the B+ pad as shown, using a ferrite bead on the far end, which attaches to the feedthrough capacitor in the PA compartment.

A ground return cable should be connected from the power supply to the ground plane of the pc board through the mounting hardware. The cable should be #18 or larger wire to minimize voltage drop. A 3 or 4 Amp, quick acting fuse should be connected in the positive supply line for protection.

A well regulated power supply should be used. Current drain of the PA at full output is about 2 Amp.

Note that the output capability of the PA drops rapidly as the voltage is reduced below 13.6Vdc; therefore, you should try to use a power source of sufficient voltage and minimize cable losses so that you have full B+ available at the PA.

CAUTIONS TO PROTECT TRANSISTORS.

Because it is so easy to damage rf power transistors in the field due to accidents and abuse, transistor manufacturers do not provide any warranty to cover replacements once a transistor is installed in the unit. They test them thoroughly at the factory because they are expensive parts and they want to be sure you get good parts with your kit. Therefore, they do not honor claims that "the transistor must have been bad from the factory". For your protection, please be sure to observe the following precautions:

1. Transistors are made to operate in specific circuits. Do not try to check with ohmmeter, etc. Sometimes, you can blow a transistor when you reverse polarity.

2. Sometimes, transistors may be destroyed by parasitic oscillations occurring during tuning because of the extremes of capacitor settings, or due to accidental shorting of components. To protect against such damage as much as possible, turn power supply voltage down to 9 or 10 Volts when you first apply power until the unit is tuned. Then, turn up to full 13.6Vdc. Of course, final tuning should be done

at full 13.6V.

3. Never exceed 13.6Vdc, as even a small over-voltage causes strain on transistors.

4. Be sure you have a low impedance connection to the power supply, i.e., short, heavy cable.

5. Do not attempt to operate PA until exciter has been properly aligned by itself, operating into a 50-ohm load.

ALIGNMENT.

Alignment is very simple. Connect the input to an exciter which has already been tuned into a 50-ohm dummy load. Connect the output to a 50-ohm load of sufficient power rating. Use an in-line power meter, or monitor output with a dc voltmeter connected to rf detector test point pad on pc board.

Preset variable capacitors as follows if this is the first time tuning from a kit; otherwise, they should be left where previously tuned. The large mica variable capacitor should be screwed down tight and then backed off about three turns. The piston trimmer capacitors in the output circuit should be adjusted so that 5/16 inch of piston screw is exposed at top. The piston trimmer capacitors in the input circuit should be adjusted so that 1/2 inch of piston screw is exposed at top.

Apply B+ and moderate rf drive. First, adjust mica variable capacitor C6 for maximum output. Then, alternately tune the various mica and piston trimmer capacitors for maximum output. Continue re-peaking capacitors until maximum output is achieved and all interactions between capacitors are worked out.

Note: If the output is less than 8-10 Watts, check to be sure that the input tuned circuits are not tuned to a false peak, which can happen if the piston capacitors in the input circuit are adjusted with only about 1/4 inch of piston exposed. The true peak (assuming operation in the 440-470 MHz range) will occur with about 1/2 inch of piston exposed.

If you happen to have a spectrum analyzer (not required), you can fine tune C8 for lowest harmonic level and re-peak C6 and C7 for maximum; otherwise, just peak all the capacitors for maximum output.

Note: Do not retune exciter with PA connected. Once the exciter is tuned into a 50-ohm load, it should never be tuned again. Tuning the input of the PA takes care of matching the PA to the

exciter.

OPERATION.

Operation is quite simple. B+ can be applied all the time if desired. Merely apply an rf signal to the PA when you want to transmit. Power output may sag about 5% as the transistor heats up, but no more. If excessive power sag occurs after heating and retuning the capacitors does not correct the problem, check to be sure the transistor is mounted properly to the heat sink surface with heat sink compound.

TROUBLESHOOTING.

Since the unit has only one simple amplifier stage, there isn't much which can go wrong. The circuitry is straightforward, with shorted coax cables or incorrect or shorted pc board component connections being the first things to suspect should there be no output.

Should it be necessary to replace rf power transistor Q1, be sure to use an exact replacement. There are other transistors rated at similar output level, but they may have lower gain or different impedance characteristics.

To replace the transistor, carefully peel each lead away from the pc board while melting the solder. Then, remove the mounting hardware and gently push the old transistor out of the heatsink. Clean all the old solder off the pc board. Add new heatsink compound, and install new transistor with collector lead in correct location. Carefully tighten nut on transistor without over-torquing. Then, flatten leads against the board, and sweat solder them to the board. Remember to resolder any components removed for access to the transistor leads.

A word about relay coils. Any relay coil connected to the same B+ line as solid state equipment should have a reverse diode connected across it to absorb the inductive kickback which occurs when the coil is de-energized. Relay coils and similar inductors can cause transients up to several hundred volts. This is the most common problem related to damaged semi-conductors. You should also be sure that your power supply does not have an inductive surge when you turn it on or off. If in doubt, borrow an oscilloscope and watch the B+ line when you turn the switch on and off.

PARTS LIST.

Ref Desig	Description (marking)
-----------	-----------------------

C1	15 pf chip capacitor
C2-C3	10 pf piston trimmer cap.
C4	not used
C5	15 pf chip capacitor
C6	mica variable #703
C7-C8	10 pf piston trimmer cap.
C9	not used
C10	.001 uf chip capacitor
C11	0.1 uf chip capacitor
C12	47 uf electrolytic cap
L1-L4	form per diagram
L5	0.22 μ h rf choke
Q1	2N5946
R1	270 ohms, 1/4W
R2	10 ohms, 1/4W
Z1, Z3	Ferrite bead (remove lead before using)
Z2	6-hole ferrite balun core wound as per text

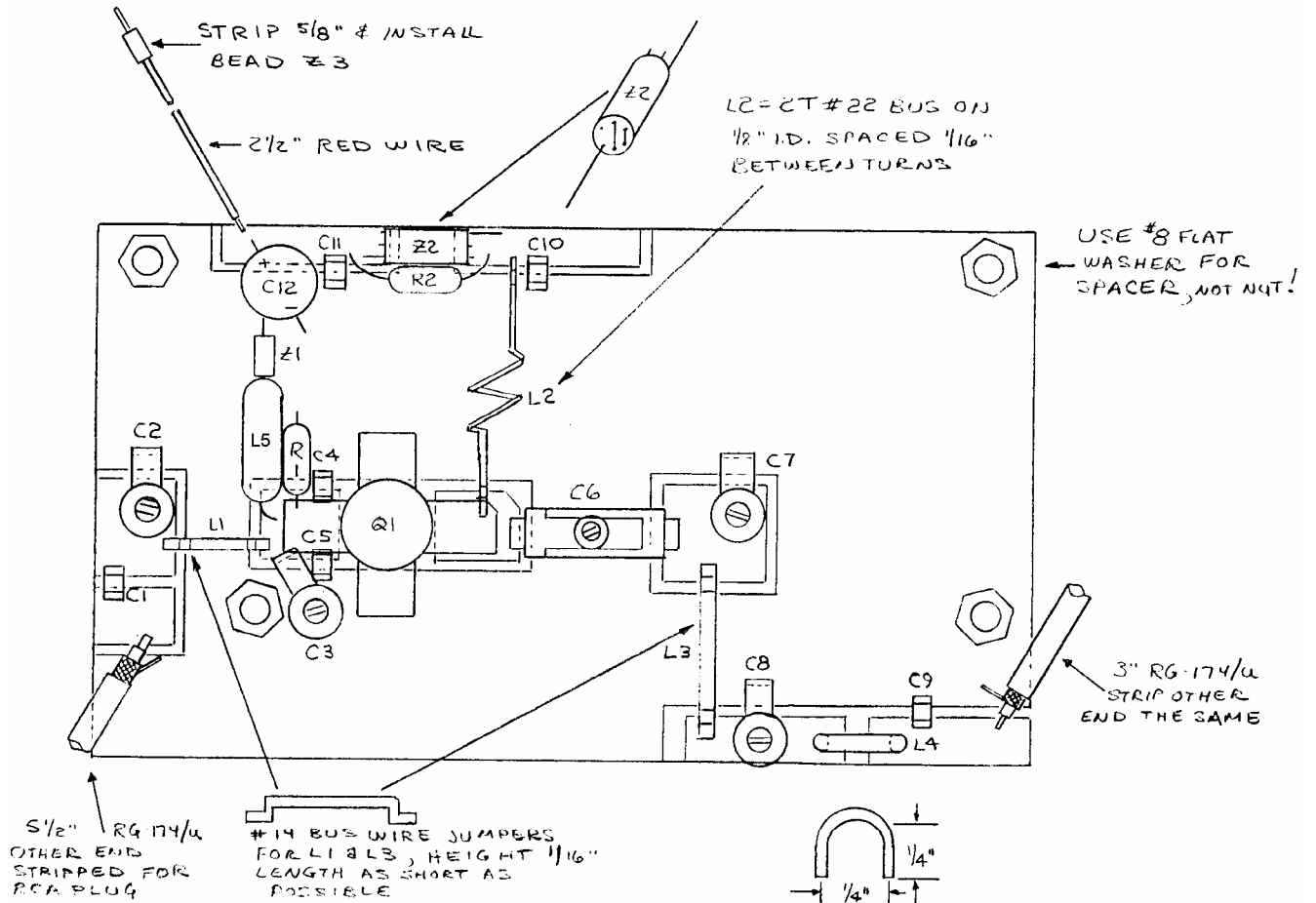

5/2" RG-174/u
OTHER END
STRIPPED FOR
RCA PLUG

#14 BUS WIRE JUMPERS
FOR L1 & L3, HEIGHT 1/16"
LENGTH AS SHORT AS
POSSIBLE

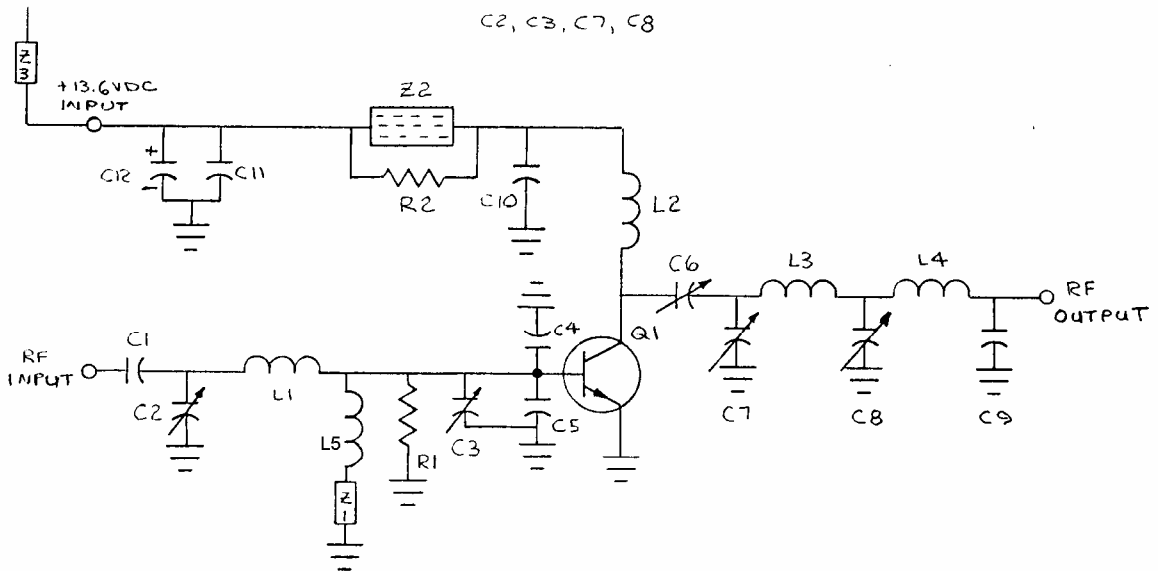
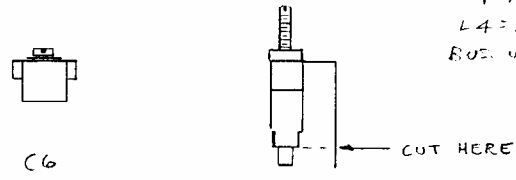
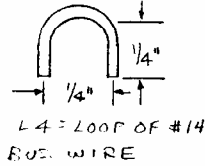

LPA 4-10R PWR AMPL