

HAMTRONICS® R303 VHF FM RECEIVER: INSTALLATION, OPERATION, & MAINTENANCE

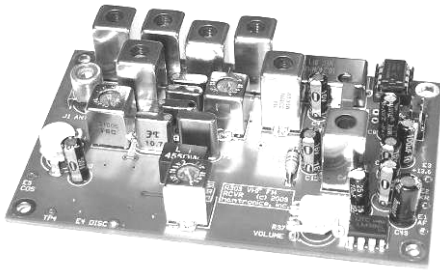

GENERAL INFORMATION.

The R303 is the latest in a series of popular receivers for demanding applications which require exceptional sensitivity and selectivity. It is especially suited for repeaters, audio and data links, and remote control. The R303 was designed to allow the factory to set it on frequency without lengthy waits to obtain channel crystals. It is a single-channel vhf fm receiver available in several models for reception in the 144 MHz ham band, the 138-175 MHz commercial band, or 216-230 MHz. On special order, up to three frequencies can be programmed into the receiver allowing jumpers to change channels.

The R303 is our 9th generation vhf fm receiver, and it packs in features you've told us are important to you during our 45 years of designing receivers. It's up to the difficult jobs you've told us you have.

The R303 retains all of the popular features Hamtronics® receivers have been noted for. It uses triple-tuned circuits in the front end and excellent crystal and ceramic filters in the i-f with steep skirts for close channel spacing or repeater operation. The i-f selectivity, for instance, is down over 100dB at ± 12 kHz away from the carrier, which is 40-50 dB better than most transceivers. Low noise fet's in the front end provide good overload resistance and excellent sensitivity.

The R303 is designed for narrow-band fm with ± 5 kHz deviation. Other bandwidths are available on special order.

The R303 features a positive-acting, wide-range squelch circuit and additional output terminals for low-level squelched audio and discriminator audio as well as COS.

The audio output will drive any load as low as 8Ω with up to 1 Watt continuous output. Volume and squelch are adjustable with trim pots on the pc board. For those applications requiring adjustments on the outside of a cabinet, you may easily replace these pots with suitable panel mount controls.

The receiver may be used with either voice or fsk data up to 9600 baud using an external data demodulator unit. An accessory TD-5 CTCSS Decoder unit is available for subaudible tone control.

There are several models, which have minor variations in parts and microcontroller programming, to provide coverage as shown in

table 1. The frequency is programmed in at the factory and is aligned to frequency; so you have no adjustments to do at installation.

The TCXO (temperature controlled xtal oscillator) provides a temperature stability of ± 2 ppm over a temperature range of -30°C to $+60^{\circ}\text{C}$.

INSTALLATION.

Mounting.

Some form of support should be provided under the pc board, generally mounting the board with spacers to a chassis. The receiver board relies on the mounting hardware to provide the dc and speaker ground connections to the ground plane on the board; so metal stand-offs and screws should be used for mounting.

Electrical Connections.

Power and input audio or data signals should be connected to the solder pads on the pc board with #22 solid hookup wire, which can be attached to a connector or feedthrough capacitors used on the cabinet in which it is installed. Be very careful not to route the wiring near the components on the left hand side of the board, which contains sensitive loop filter and vco circuits which could pick up noise from the wiring.

Power Connections.

The receiver operates on +13.6 Vdc at about 100 mA peak with full audio. Current drain with no audio is only about 38 mA. A well regulated power supply should be used.

Be sure that the power source does not carry high voltage or reverse polarity transients on the line, since semiconductors in the receiver can be damaged. The positive power supply lead should be connected to the receiver at terminal E3, and the negative power lead should be connected to the ground plane of the board through the mounting hardware or the shield of the coaxial cable. Be sure to observe polarity!

Speaker.

An 8-ohm loudspeaker should be connected to E2 with ground return through the mounting hardware. Use of lower impedance speaker or shorting of speaker terminal can result in ic damage. The receiver can also drive higher impedances, such as the 1K to 20K input impedances of repeater controller boards.

Antenna Connections.

The antenna connection should be made to the pc board with an RCA plug of the low-loss type made for rf. We sell good RCA plugs with cable clamp. See A5 plug on website.

If you want to extend the antenna connection to a panel connector, we recommend using a short length of RG-174/u coax with the plug and keep the pigtailed very short.

We do **not** recommend trying to use direct

coax soldered to board or another type of connector. The method designed into the board results in lowest loss practical. When soldering the cable, keep the stripped ends as short as possible.

• We recommend you always use antennas with a matching network which provides a dc ground on the driven element to avoid static buildup damaging the input stage of the receiver.

OPTIONS.

Repeater Use.

E5 provides a COS (carrier operated switch) output which may be connected to a COR module to turn a transmitter on and off. The output level is about 5V unsquelched and 0V squelched. There is a resistor in series with the output to limit current. Therefore, the voltage that appears at the COR board will depend on the load resistance at the input of that board. For best results, be sure that the input resistance of the COR board is at least 47K. If the input resistance is too low, no damage to the receiver will occur; but the squelch circuit hysteresis will be affected.

If your repeater controller uses discriminator audio, rather than the speaker output, filtered discriminator audio is available at E4. The level is about 2V p-p. *Note that discriminator audio is not de-emphasized or squelched.*

If your controller uses low level audio and has a high input impedance (20K or higher), squelched audio can be obtained from Repeater Audio terminal E1 independent of the volume control.

Subaudible Tone Decoder.

To use our TD-5 Subaudible Tone Decoder or a similar module, connect its audio input to *DISCRIMINATOR* terminal E4. If you want to use it to mute the audio (instead of inhibiting a repeater transmitter as is normally done), connect the mute output of the TD-5 to E1 on the receiver.

Table 1. Quick Specification Reference

Frequency Range: Can be supplied for any frequency in range of 138-175MHz or 216-230MHz.
Sensitivity (12dB SINAD): 0.15 to 0.2 μV
Squelch Sensitivity: 0.15 μV
Normal signal bw: ± 5 kHz deviation
Adjacent Channel Selectivity: ± 12 kHz at -100dB (narrower bandwidth available as an option)
Image Rejection: 60-70dB
Modulation Acceptance: ± 7.5 kHz
Frequency Stability: ± 2 ppm -30°C to $+60^{\circ}\text{C}$
Audio Output: up to 1 Watt (8 ohms).
Operating Power: +13.6Vdc (+10 to +15Vdc) at 38-100 mA, depending on audio level.
Size: 4 in. W x 2-1/2 in. D

Multichannel Operation.

The R303 may be supplied with more than one channel. If you ordered this option, you can change to one alternate channel by grounding E6 or the second alternate channel by grounding E7. Ground terminals E8 and E9 are provided if you want to use jumpers, or you can use an external switch of some sort.

ADJUSTMENTS.

Frequency Netting.

All crystals age a little over a long period of time; so it is customary to tweak any receiver back onto the precise channel frequency once a year during routine maintenance. Because modern solid state equipment doesn't require much routine maintenance, many receivers don't get their oscillators tweaked as a matter of routine any more, but they should.

The adjustment should be done using an accurate service monitor or frequency counter. Of course, make sure the test equipment is exactly on frequency first by checking it against WWV or another frequency standard.

The channel frequency is trimmed precisely on frequency with a small variable capacitor, which is accessible through a hole in the top of the shield can on the TCXO. The proper tool is a plastic wand with a small metal bit in the end.

To perform this adjustment, it is first necessary to verify that the discriminator is properly adjusted. Do this by connecting a dc voltmeter to E4. Connect a signal generator set for 10.700 MHz to TP3, and set the level for a relatively strong signal so there is very little white noise. Adjust discriminator coil T3 for 2Vdc. Then, reconnect the signal generator to antenna connector J1, and set it for the precise channel frequency. You can also use a strong signal on the air if you are sure it is right on frequency. Adjust the TCXO capacitor for 2Vdc (to match the voltage obtained with the 10.700 MHz signal).

Setting Channel Frequency.

The channel frequency is determined by frequency synthesizer circuits, which use a microcontroller which is programmed at the factory. If you need to change frequency, contact the factory to get another micro programmed for the new frequency settings.

ALIGNMENT.

General Procedure.

A complete alignment is needed whenever the frequency is changed by more than 1 MHz. Alignment ensures that the frequency synthesizer is optimized at the center of the vco range and that all stages are tuned to resonance.

Equipment needed for alignment is a sensitive dc voltmeter, a stable and accurate signal generator for the channel frequency, and a regulated 13.6Vdc power supply with a 0-200 mA meter internally or externally connected in the supply line.

The slug tuned coils in the Receiver should be adjusted with the proper tuning tool to

avoid cracking the powdered iron slugs. Variable capacitors should be adjusted with a plastic tool having a small metal bit. (See A1, A2, and A28 tools on our website.) All variable capacitors should be set to the center of their range. Turn them 90° if they have not previously been aligned (except on the optional TCXO).

Note: Meter indications used as references are typical but may vary widely due to many factors not related to performance, such as type of meter and circuit tolerances. Typical test point indications are for the 144 MHz band unit and may differ for other bands.

a. Set the SQUELCH pot fully counterclockwise and the VOLUME pot just a little clockwise.

b. Connect speaker and +13.6 Vdc. You should hear white noise.

c. Connect voltmeter to TP1. Adjust vco coil L1 for +2.0Vdc. (Although the vco will operate over a wide range of tuning voltages from about 0.5V to 4.5V, operation is optimum if the vco is adjusted to 2.0V.)

d. Connect voltmeter to TP2. Adjust buffer coil L3 for a peak, typically about +0.35V.

e. Connect signal generator to TP-3. Use a frequency counter or synthesized signal generator. Set generator to exactly 10.7000 MHz. Set level just high enough for full quieting. At 1 uV, you should notice some quieting, but you need something near full quieting for the test (about 20µV).

f. Connect dc voltmeter to Discriminator terminal E4. Adjust discriminator transformer T2 for +2Vdc.

Note: Be careful not to turn the slug tight against either the top or bottom because the winding of the transformer can be broken. The tuning response is an S-curve; so if you turn the slug several turns, you may think you are going in the proper direction even though you are tuning further away from center frequency.

g. Connect signal generator to J1 using a coax cable with RCA plug. Adjust signal generator to exact channel frequency, and turn output level up fairly high (about 1000µV). Adjust frequency trimmer in TCXO (if necessary) to net the crystal to channel frequency, indicated by +2Vdc at E4.

Note: There are two methods of adjusting the mixer and front end. One is to use a voltmeter with test point TP-4. The voltage at this point is proportional to the amount of noise detected in the squelch circuit; so it gives an indication of the quieting of the receiver. With SQUELCH control fully ccw, the dc voltage at TP-4 varies from -0.5 Vdc with no signal (full noise) to +1 Vdc with full quieting signal.

The other method is to use a regular professional SINAD meter and a 1000 Hz tone with 3 kHz deviation

In either case, a weak to moderate signal is required to observe any change in noise. If the signal is too strong, there will be no change in the reading as tuning progresses; so keep the signal generator turned down as receiver sensitivity increases during tuning.

h. Connect fet dc voltmeter to TP4 or observe sinad meter. Set signal generator for relatively weak signal, one which shows some change in indication. Alternately peak RF amplifier and mixer coils L4-L8 until no further improvement can be made.

When properly tuned, sensitivity should be about 0.15 to 0.2µV for 12 dB SINAD.

Crystal filter trimmer coils T1 and T2 normally should not be adjusted. They are set at the factory. The purpose of the adjustment is to provide proper loading for the crystal filter, and if misadjusted, ripple in the filter response will result in a little distortion of the detected audio. If it becomes necessary to adjust T1 and T2, tune the signal generator accurately on frequency with 5kHz fm deviation using a 1000 Hz tone. In order of preference, use either a SINAD meter, an oscilloscope, or just your ears, and fine tune T1 and T2 for minimum distortion of the detected audio.

THEORY OF OPERATION.

The R303 is a frequency synthesized vhf fm Receiver. Refer to the schematic diagram for the following discussion.

Low noise dual-gate mos fet's are used for the RF amplifier and mixer stages. The output of mixer Q5 passes through an 8-pole crystal filter to get exceptional adjacent channel selectivity.

U4 provides IF amplification, a 2nd mixer to convert to 455 kHz, a discriminator, noise amplifier, and squelch. Ceramic filter FL5 provides additional selectivity at 455 kHz. The noise amplifier is an op amp active filter peaked at 10 kHz. It detects noise at frequencies normally far above the voice band. Its output at pin 11 is rectified and combined with a dc voltage from the SQUELCH control to turn a squelch transistor on and off inside the ic, which grounds the audio path when only noise is present. Inverter Q6 provides a dc output for use as a COS signal to repeater controllers.

The injection frequency for the first mixer is generated by vco (voltage controlled oscillator) Q1. The injection frequency is 10.700 MHz below the receive channel frequency. The output of the vco is buffered by Q2 to minimize effects of loading and voltage variations of following stages from modulating the carrier frequency. The buffer output is applied through a double tuned circuit to gate 2 of mixer Q5.

The frequency of the vco stage is controlled by phase locked loop synthesizer U2. A sample of the vco output is applied through the buffer stage and R1 to a prescaler in U2. The prescaler and other dividers in the synthesizer divide the sample down to 5kHz. A reference frequency of 10.240 MHz is generated by a TCXO (temperature compensated crystal oscillator). The reference is divided down to 5 kHz. The two 5kHz signals are compared to determine what error exists between them. The result is a varying dc tuning voltage used to phase lock the vco precisely onto the desired channel frequency.

The tuning voltage is applied to varactor diode D1, which varies its capacitance to tune the tank circuit formed by L1/C15/C16. C12 limits the tuning range of D1. The tuning voltage is applied to D1 through a third order low pass loop filter, which removes the 5kHz reference frequency from the tuning voltage to avoid whine. In order for the synthesizer to lock, the vco must be tuned to allow it to generate the proper frequency within the range of voltages the phase detector in the synthesizer can generate, roughly 0.5Vdc to 4.5Vdc.

Serial data to indicate the desired channel frequency and other operational characteristics of the synthesizer are applied to synthesizer U2 by microcontroller U1. Everything the synthesizer needs to know about the band, division schemes, reference frequency, and oscillator options is generated by the controller. Information about the base frequency of the band the receiver is to operate on and the channel within that band is calculated in the controller based on information programmed in the eeprom on the controller. Whenever the microcontroller boots at power up, the microcontroller sends several bytes of serial data to the synthesizer, using the data, clock, and /enable lines running between the two ic's. Terminals E6 & E7 allow alternate frequencies to be selected for those receivers programmed to use that feature.

+13.6Vdc power for the Receiver is applied at E1. Audio output amplifier U5 is powered directly by the +13.6Vdc. All the other stages are powered through 5V regulator U6 for stability and to eliminate noise. Additional filtering for the vco and buffer stages is provided by capacitance amplifier Q3, which uses the characteristics of an emitter follower to provide a very stiff supply, eliminating any possible noise on the power supply line.

TROUBLESHOOTING.

General.

The usual troubleshooting techniques of checking dc voltages and signal tracing with an RF voltmeter probe and oscilloscope will work well in troubleshooting the R303. DC voltage charts and a list of typical audio levels are given to act as a guide to troubleshooting. Although voltages may vary widely from set to set and under various operating and measurement conditions, the indications may be helpful when used in a logical troubleshooting procedure.

Current Drain.

Power line current drain normally is about 38 mA with volume turned down or squelched and up to 100 mA with full audio output.

If the current drain is approximately 100 mA with no audio output, check to see if voltage regulator U6 is hot. If so, and the voltage on the 5V line is low, there is a short circuit on that bus somewhere and U6 is limiting the short circuit current to 100mA to protect the receiver from damage. If you clear the short circuit, the voltage should rise again. U6 should not be damaged by short circuits on its

output line; however, it may be damaged by reverse voltage or high transient voltages.

Audio Output Stage.

Note that audio output ic U5 is designed to be heatsunk to the pc board through the many ground pins on the ic.

If audio is present at the volume control but not at the speaker, the audio ic may have been damaged by reverse polarity or a transient on the B+ line. This is fairly common with lightning damage.

If no audio is present on the volume control, the squelch circuit may not be operating properly. Check the dc voltages, and look for noise in the 10 kHz region, which should be present at U1-pin 11 with no input signal. (Between pins 10 and 11 of U1 is an op-amp active filter tuned to 10 kHz.)

RF Signal Tracing.

If the receiver is completely dead, try a 10.700 MHz signal applied to TP-3 using coax test lead. Set level just high enough for full quieting. At 1 μ V, you should notice some quieting, but you need something near full quieting for the test.

You can also connect the 10.700 MHz test lead through a blocking capacitor to various sections of the crystal filter to see if there is a large loss of signal across one of the filter sections. Also, check the 10.245 MHz oscillator with a scope or by listening with an hf receiver or service monitor.

A signal generator on the channel frequency can be injected at various points in the front end. If the mixer is more sensitive than the RF amplifier, the RF stage is suspect. Check the dc voltages looking for a damaged fet, which can occur due to transients or reverse polarity on the dc power line. Also, it is possible to have the input gate (gate 1) of the RF amplifier fet damaged by high static charges or high levels of RF on the antenna line, with no apparent change in dc voltages, since the input gate is normally at dc ground.

Synthesizer Circuits.

Following is a checklist of things to look for if the synthesizer is suspected of not performing properly.

a. Check the output frequency of the vco buffer with a frequency counter.

c. Check tuning voltage at TP1. It should be about +2.0Vdc. Actual range over which the unit will operate is about +0.5Vdc to about +4.5Vdc. However, for optimum results, the vco should be tuned to allow operation at about +2.0Vdc center voltage.

d. Check the operating voltage and bias on the vco and buffer.

e. Check the TCXO at pin 1 of the synthesizer ic. A scope should show strong signal (1.5 Vp-p) at 10.240 MHz.

f. The data, clock, and latch enable lines between the microcontroller and synthesizer ic's should show very brief and very fast activity, sending data to the synthesizer ic shortly after the power is first applied or a dip switch setting is changed. Because this happens very

fast, it can be difficult to see on a scope. Use 1mSec/div, 5Vdc/div, and normal trigger.

Microphonics, Hum, and Noise.

The vco and loop filter are very sensitive to hum and noise pickup from magnetic and electrical sources. Some designs use a shielded compartment for vco's. We assume the whole board will be installed in a shielded enclosure; so we elected to keep the size small by not using a separate shield on the vco. However, this means that you must use care to keep wiring away from the vco circuit at the right side of the board. Having the board in a metal enclosure will shield these sensitive circuits from florescent lights and other strong sources of noise.

Because the frequency of a synthesizer basically results from a free running L-C oscillator, the tank circuit, especially L1, is very sensitive to microphonics from mechanical noise coupled to the coil. You should minimize any sources of vibration which might be coupled to the receiver, such as motors. In addition, it helps greatly to prevent the molded coil from vibrating with respect to the shield can. Both the coil and can are soldered to the board at the bottom, but the top of the coil can move relative to the can and therefore cause slight changes in inductance which show up as frequency modulation. Therefore, the factory cements the top of the coil to the can.

Excessive noise on the dc power supply which operates the receiver can cause noise to modulate the synthesizer output. Various regulators and filters in the receiver are designed to minimize sensitivity to wiring noise. However, in extreme cases, such as in mobile installations with alternator whine, you may need to add extra filtering in the power line to prevent the noise from reaching the receiver.

To varying degrees, whine from the 5kHz reference frequency may be heard on the signal under various circumstances. If the tuning voltage required to tune the vco on frequency is very high or low, near one extreme, the whine may be heard. This can also happen even when the tuning voltage is properly near the 2.0Vdc center if there is dc loading on the loop filter. Any current loading, no matter how small, on the loop filter causes the phase detector to pump harder to maintain the tuning voltage. The result is whine on the signal. Such loading can be caused by connecting a voltmeter to TP1 for testing, and it can also be caused by moisture on the loop filter components.

Typical Dc Voltages.

Tables 2-4 give dc levels measured with a sensitive dc voltmeter on a sample unit with 13.6 Vdc B+ applied. All voltages may vary considerably without necessarily indicating trouble. The charts should be used with a logical troubleshooting plan. All voltages are positive with respect to ground except as indicated.

Use caution when measuring voltages on the surface mount ic. The pins are close together, and it is easy to short pins together and

damage the ic. Try to connect meter to a nearby component connected to the pin under question.

Typical Audio Levels.

Table 5 gives rough measurements of audio levels. Measurements were taken using an oscilloscope, with no input signal, just white noise so conditions can be reproduced easily.

TP1	Tuning V.	Normally set at 2V
TP2	Buffer	approx. 0.3 – 0.6V
TP3	Test Input	(No reading)
TP4	Sig. Level	With SQUELCH control fully ccw, varies from -0.3 Vdc with no to +0.9 Vdc full quieting.
E4	Freq.	Varies with frequency of input signal. Voltage at this point normally is adjusted for +2Vdc with a signal exactly on frequency. Can vary a little without being a problem.

Xstr	Stage	E(S)	B(G1)	C(D)	G2
Q1	vco	0.9	1.6	3.8	-
Q2	buffer	0	0.7	2.4	-
Q3	dc filter	4.1	4.8	5	-
Q4	RF ampl	0	0	4.6	2.3
Q5	Mixer	0	0	4.9	0
Q6	sq. open	0	0	5	-
	sq. closed	0	0.65	0.14	-

U2-1	2.4	U4-1	5
U2-2	2.4	U4-2	4.4
U2-3&4	5	U4-3	4.8
U2-5	0 – 5V (~2V tuned)	U4-4	5
		U4-5	3.8
U2-7	5	U4-6	3.8
U2-8	1.6	U4-7	3.8
U2-9	0	U4-8	5
U2-10	0	U4-9	2 (aligned)
U2-11	0	U4-10	0.8
		U4-11	2
U5-1	1.4	U4-12	0.6 (with squelch just closed)
U5-3	0.01		
U5-5	6	U4-13	0 (sq open)
U5-6	13.6		7.5 (squelch closed)
U5-7	7	U4-14	0
U5-8	1.4	U4-15	0
		U4-16	1.8

Audio Test Point	Normal Level
U4-9 (Discriminator)	3V p-p audio
E4 (Disc Output)	2V p-p audio
E1 (Repeater Output)	1V p-p audio
U4-11 (noise ampl)	3V p-p noise
CW lug of Vol cont.	400mV p-p audio
U5-3 (af ampl input)	0 to 200mV p-p
U5-6 or E2 (speaker ampl output)	0 to 7V p-p audio

PARTS LIST FOR R303 RECEIVER.

Note: Values which vary with freq. band are shown in a table at the end of the parts list. Resistors and capacitors are 0805 or 0603 smt type unless noted otherwise.

Caution: IC's are static sensitive. Use appropriate handling precautions to avoid damage.

Ref Desig	Value (marking)
C1	0.1µf
C2	100pf
C3	0.1µf
C4	100µf electrolytic
C5	0.15µf mylar (red)
C6	.01µf
C7	.001uf
C8-C9	100µf electrolytic
C10	0.1µf
C11	390pf
C13	100µf electrolytic
C14	390pf
C17	7pf
C18	390pf
C21	2pf
C24-C25	390pf
C32	4pf
C35	.01µf
C36	7pf
C37	n/u
C38	7pf
C39	.001uf
C40	0.47µf electrolytic
C41	0.1µf
C42-C43	.001µf
C44-C45	.01µf
C46	0.1µf
C47	10µf electrolytic
C48	0.1µf
C49	220µf electrolytic
C50	68pf
C51	220pf
C52-C54	0.1µf
C55-C56	100µf electrolytic
D1	BB132 varactor diode
D2	MSC3130 (used as diode)
D3-D4	MMBT3904 (used as diode)
FL1-FL4	10.7MHz crystal filter (matched set of 4)
FL5	LT455DW ceramic filter
J1	RCA Jack
J2	6 pin header
L2	0.33µH RF choke (red-sil-orn-orn)
L3-L8	2½ t. ,slug tuned (red)
L9	0.33µH RF choke (red-sil-orn-orn)
Q1-Q2	MSC3130
Q3	MMBT3904
Q4-Q5	BF998 MOS FET
Q6	MMBT3904

R1	180Ω
R2	27Ω
R3	10K
R4	47K
R5	27Ω
R6	1K
R7	27Ω
R8-R10	10K
R11	180Ω
R12	47Ω
R13	10K
R14	3.9K
R15	470Ω
R16	1meg
R17	1K
R18	10Ω
R19-R20	100K
R21	27Ω
R22	47K
R23	27Ω
R24	330K
R25	100K trim pot
R26	47K
R27	100K
R28	15K
R29	2meg
R30	47K
R31	510K
R32	4.7K
R33	680Ω
R34	1K
R35	22K
R36	100K
R37	100K trim pot
R38	47K
R39	10Ω
T1-T2	10.7MHz IF xfmr (T1005)
T3	455kHz IF xfmr (T1003)
U1	MC9RS08KA1CP µP
U2	LMX1501A PLL
U3	10.240 MHz TCXO
U4	MC3361BPD IF ampl
U5	LM386N-1 AF output
U6	78L05ACD regulator
XU1	8 pin ic socket
Y1	10.245 MHz crystal

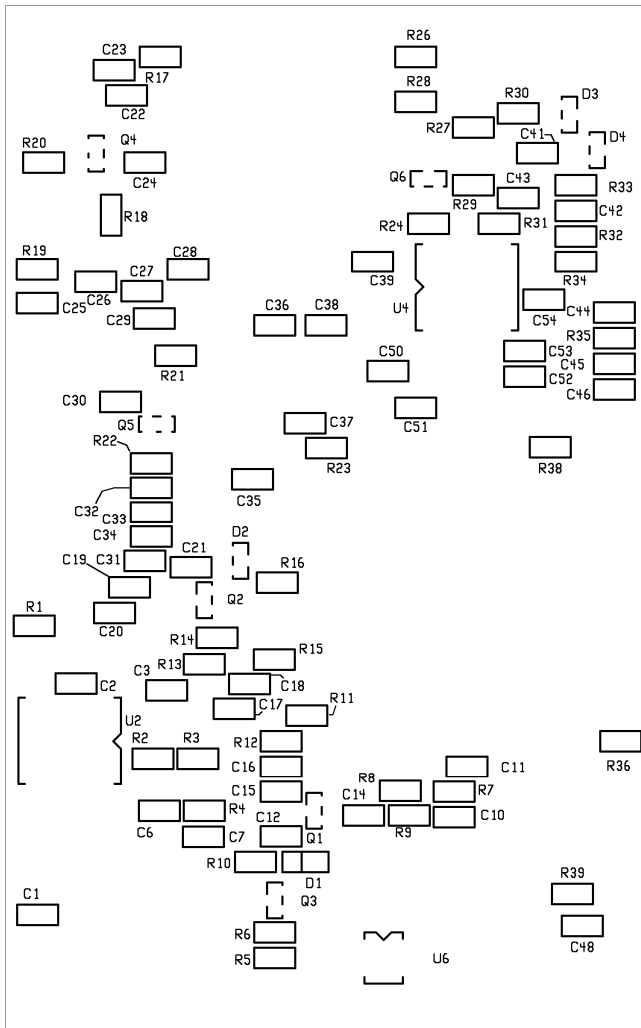

Values which vary with frequency band:

- R303-1 is 138 - 144 MHz
- R303-2 is 144 - 154 MHz
- R303-3 is 154 - 164 MHz
- R303-4 is 164 - 174 MHz
- R303-5 is 216 - 230 MHz

Ref	-1	-2	-3	-4	-5
C12		10			8
C15		15			10
C16		68			47
C19		39			12
C20		68			33
C22		27			8
C23		68			27
C26		20			7
C27		0.5			0.3
C28		22			10
C29		0.5			n/u
C30		20			7
C31		2			1
C33		30			10
C34		82			27
L1	2½t (red)	2½t (red)	2½t (red)	2½t (red)	1½t (dark brown)

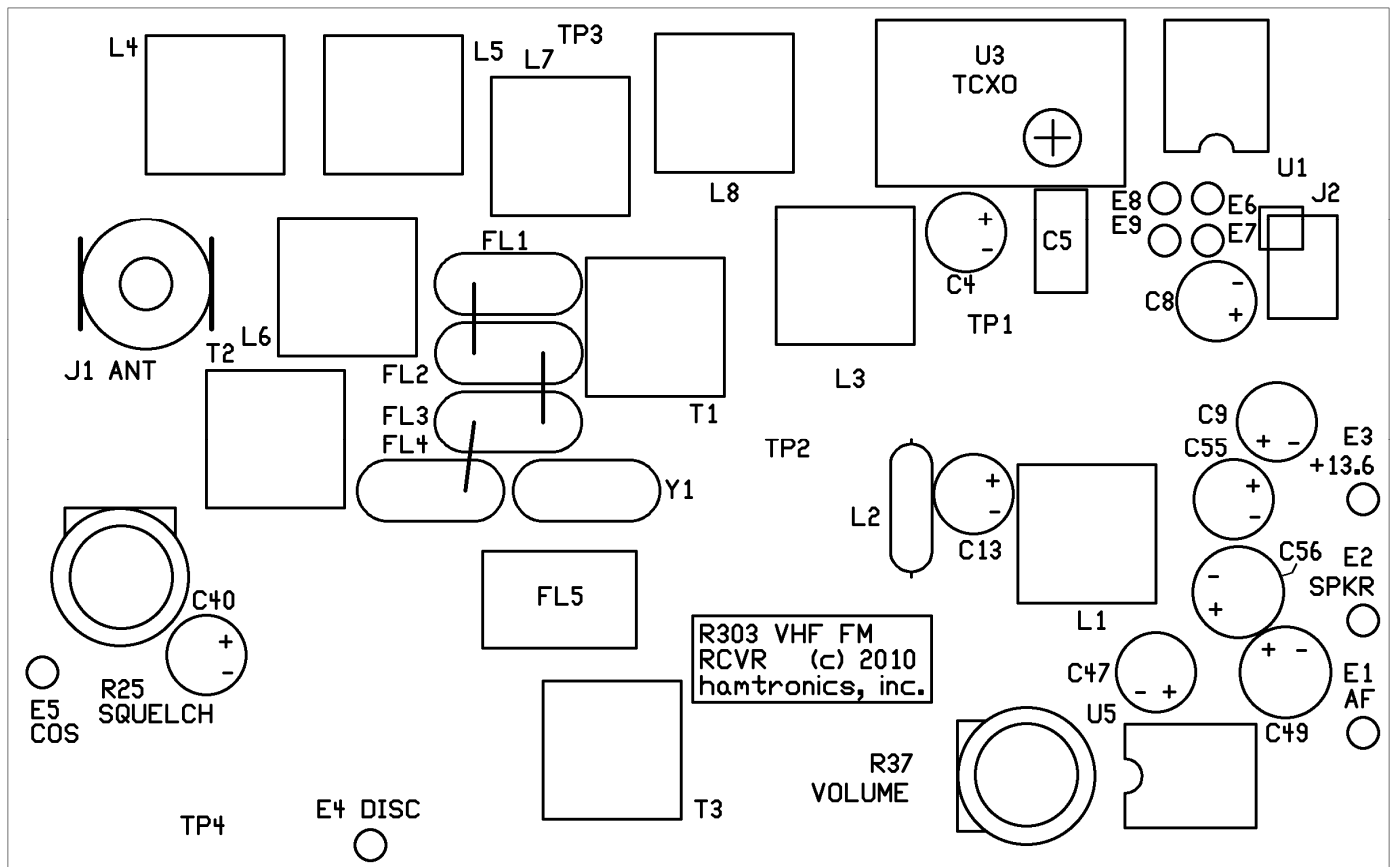

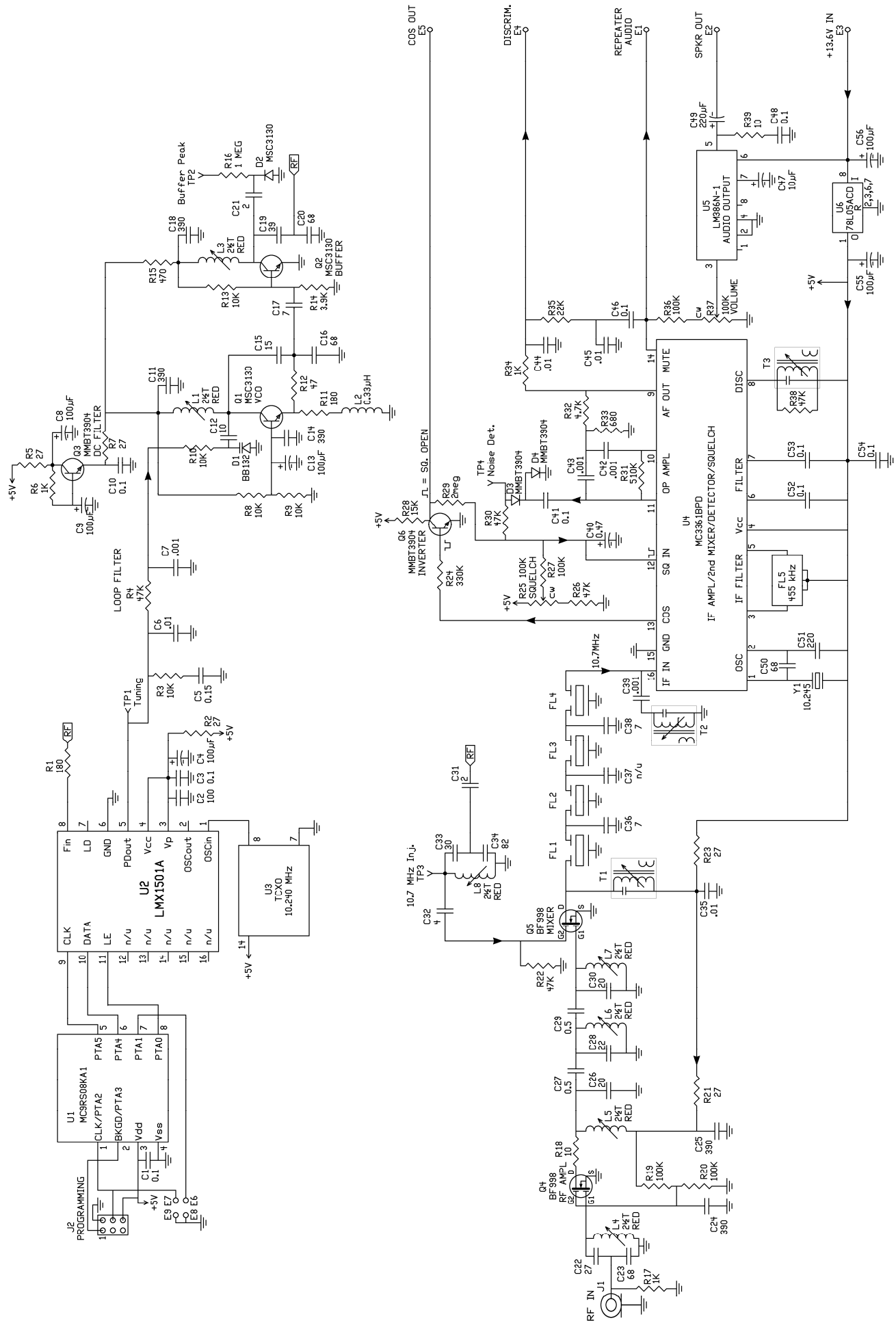

Figure 3. R303 VHF FM Receiver, Schematic Diagram.
 (Note: Values are for 144MHz version. See parts list for other bands.)